

Detail "A"

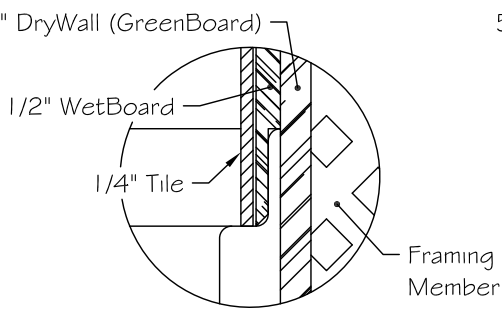

Finish Out Of Detail "A"
(For Tile Applications)

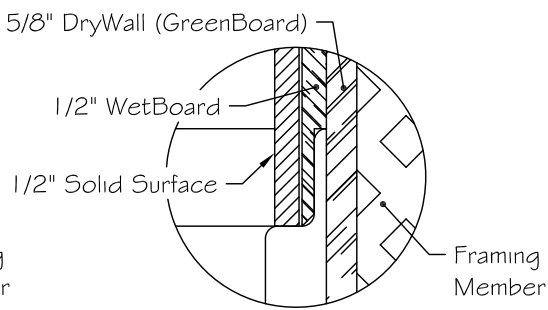

Finish Out Of Detail "A"
(For Solid Surface Applications)

Notes:

Manufacturing Tolerances Listed On O.D. Dimensions Of Unit. Field Conditions Should Be Set To Allow For Tolerances Of Unit.

If Convertible Fold-Up Seat Option is Chosen, A Mounting Plate Will Be Factory Installed On The Base. The Plate & Weld Nuts Will Add To The O.D. Dimension (Width). Field Conditions Should Be Set To Allow For This Tolerance.

Note: Left Hand Unit Shown

"Version A" - Ribbed Bottom

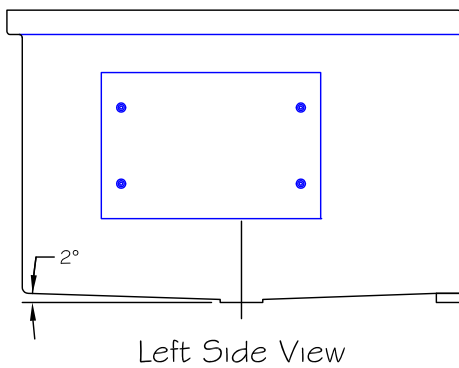
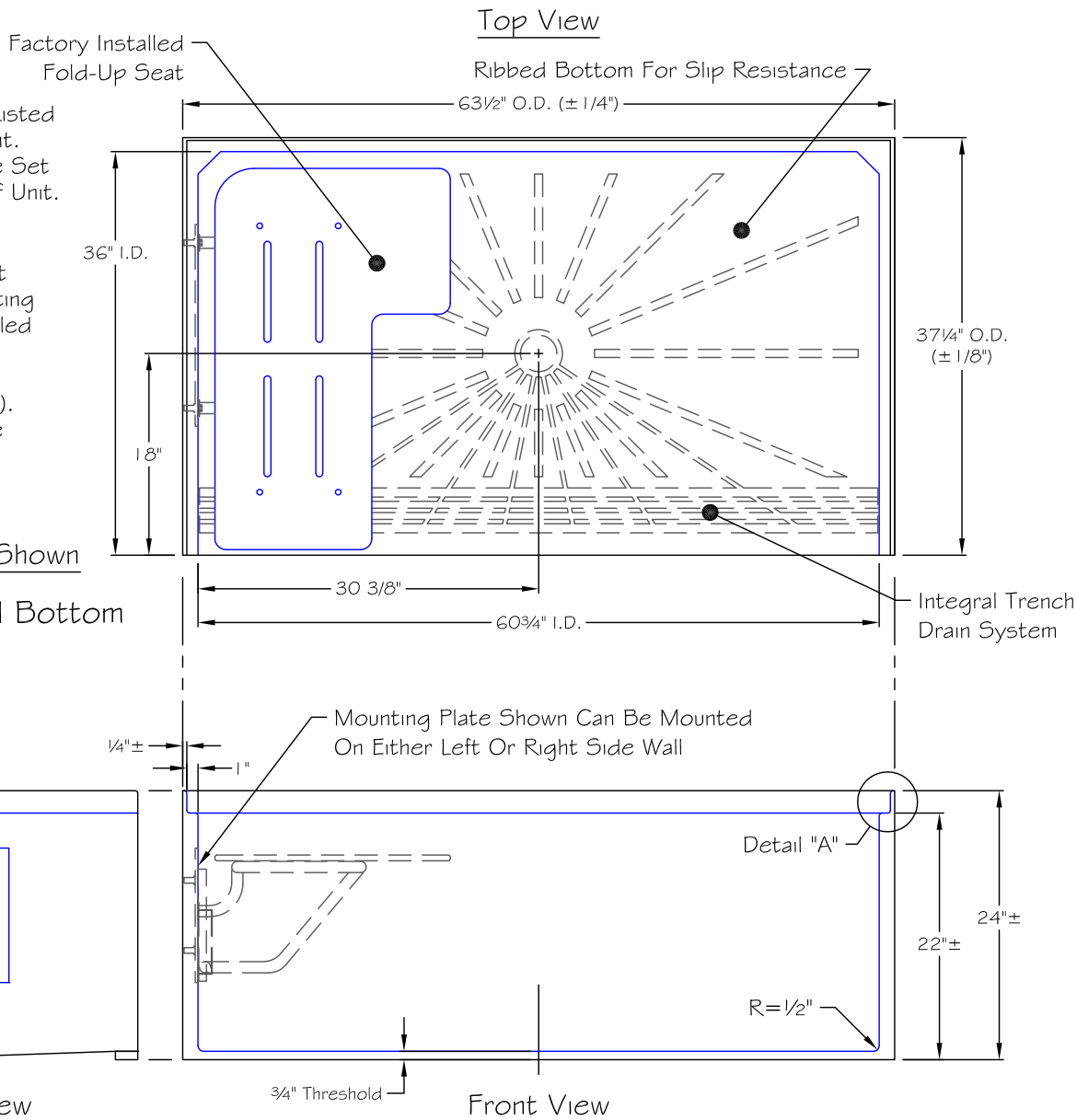

Left Side View

Front View

				<h1>AQUA BATH CO.</h1> <p>921 CHEROKEE AVENUE NASHVILLE, TN 37207</p>	
REV.	DR.	DATE	DESCRIPTION	TITLE: Roll-In Shower Base	
				DRN BY:	
				DATE:	
				MODEL NO.: B6036BF-FUS 3/4"	
				DRWG NO.:	SCALE: 3/4" = 1'-0"