

Notes:

1. Right Hand Shown.

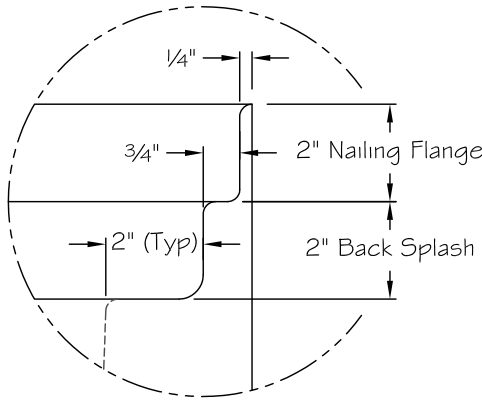

Detail "A"

Scale: 3" = 1'-0"

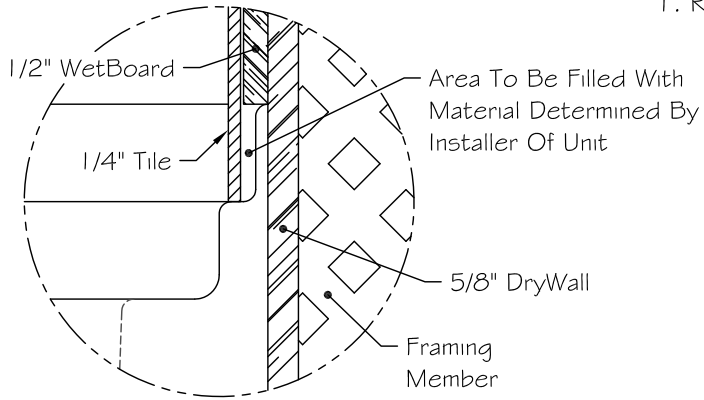

Finish Out Of Detail "A"

Scale: 3" = 1'-0"

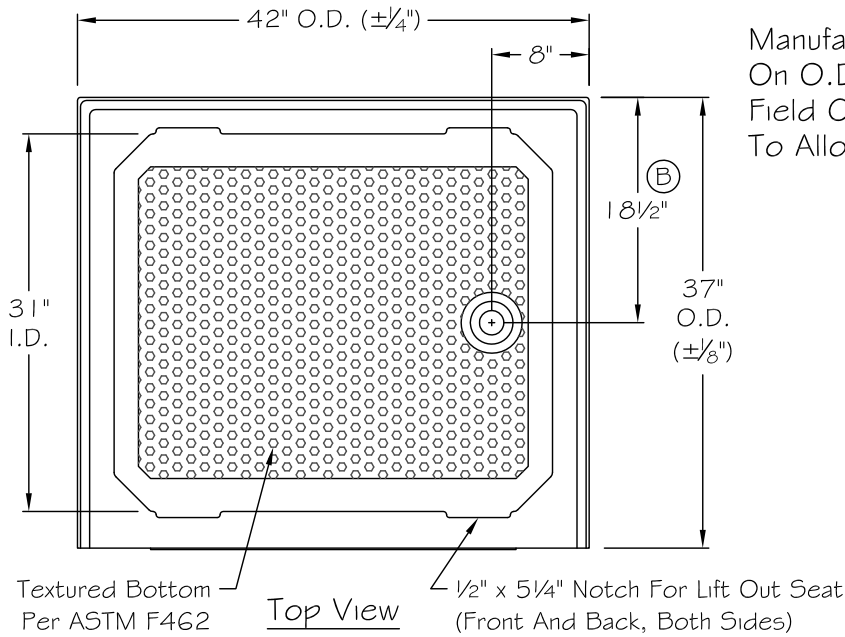

Top View

Manufacturing Tolerances Listed On O.D. Dimensions Of Unit. Field Conditions Should Be Set To Allow For Tolerances Of Unit.

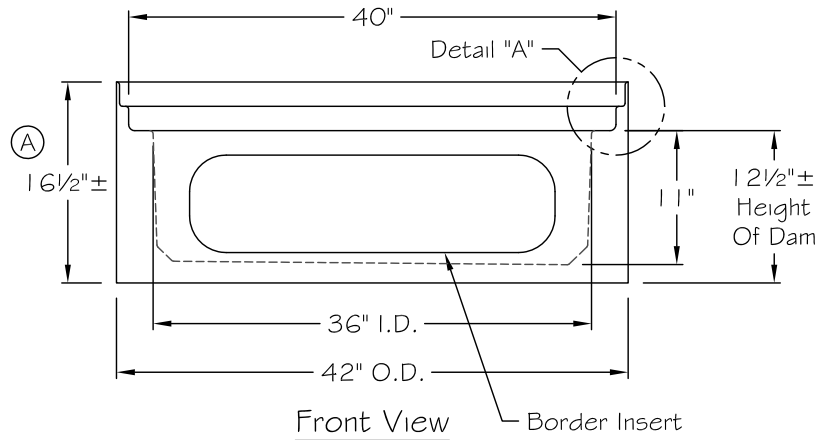

Front View

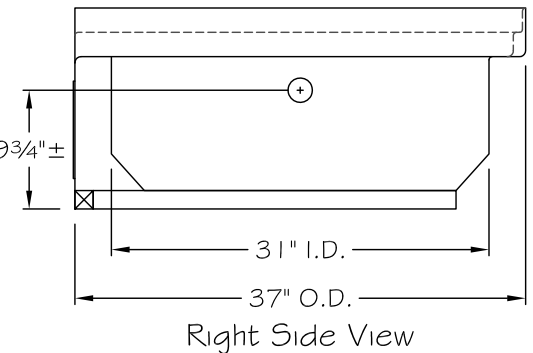

Right Side View

REV.	DR.	DATE	DESCRIPTION

AQUA BATH CO.

921 CHEROKEE AVENUE
NASHVILLE, TN 37207

TITLE: Pediatric Tub (Drywall Flange and Back Splash)	DRN BY:
MODEL NO.: P4237TS	DATE:
DRWG NO.:	SCALE: 3/4" = 1'-0"